



**MODEL 210**  
**RADIO COMMUNICATION SYSTEM**  
**INSTALLATION & OPERATION MANUAL**





# TABLE OF CONTENTS

Overview .....	2
Features .....	3
Installation .....	4
System Wiring .....	5
Overview .....	5
Power Connections .....	6
CA Cable Routing .....	6
Headset Module Installation .....	6-7
Daisy-Chaining Headset Modules .....	7
Foot Switch (optional) .....	8
Radio Connections .....	8
Settings .....	9
Operation .....	10
Troubleshooting .....	11-12
Options and Accessories .....	13
Specifications .....	13
Appendix A-Wiring Diagrams .....	13-14
Appendix B-RJ-12 Connector Assembly .....	15
Warranty .....	16

## OVERVIEW

Firecom's 210 intercom is designed for use in rugged, demanding environments. The Firecom 210 enables clear communication between up to two occupants and a 2-way radio. It is ideal for mobile equipment with complex internal and external communication requirements and high-noise environments. When used with Firecom noise attenuating headsets, the system provides protection from hearing loss that occurs when exposed to high noise levels. The 210 intercom is a durable solution for vehicles requiring occupant and radio communication.

Individual headsets determine audio transmission with the push of a button, as well as independent volume control. All headsets hear intercom traffic and are capable of intercom transmission. When a radio is connected to the system, all participants hear the radio, but only those with radio transmit headsets can transmit over the radio.

# FEATURES

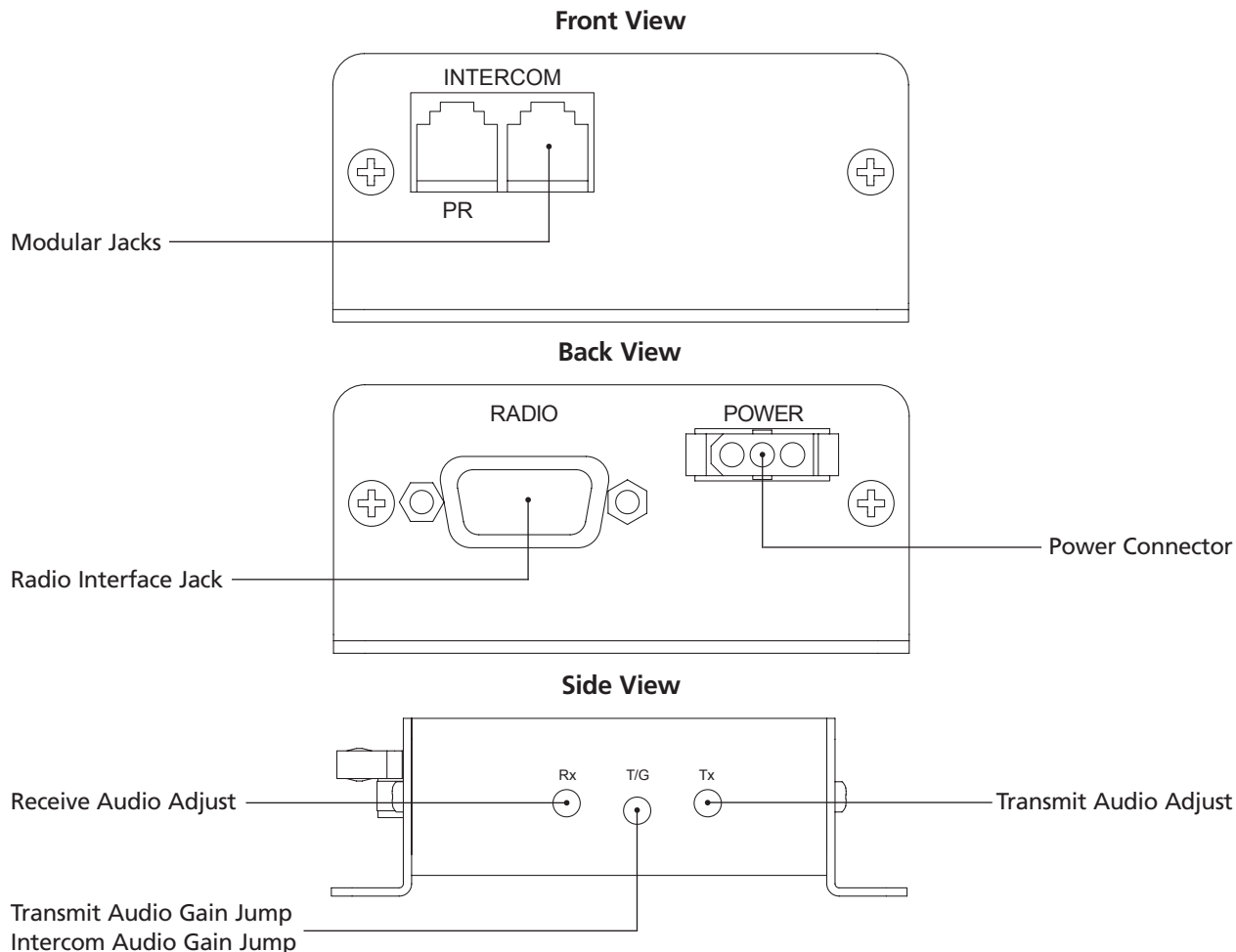

## Modular Jacks

The modular jacks are the connection points for the CA cables leading from the intercom to the headset modules.

A radio transmit priority "PR" port is identified as one of the modular jacks. When a mobile radio is connected to the system, the intercom user on this port will have priority when transmitting. Other users will not be able to transmit over the radio during this user's transmission.

## Radio Interface Jack

The 9-pin D-Sub connector is an attachment point for the included mobile radio (MR) interface cable.

## Power Connector

The 3-pin connector is the attachment point for vehicle power. A power connection cable is provided.

## Receive Audio Adjust

A rotational adjustment for setting the level of audio received to the intercom from a mobile radio.

## Transmit Audio Gain Jump / Intercom Audio Gain Jump

Two dip switches are provided for incremental gain increases of both the radio transmit audio and the intercom audio.

## Transmit Audio Adjust

A rotational adjustment for setting the level of audio transmitted to an appropriate level for a mobile radio.

# INSTALLATION

## Mounting the Intercom

Mount the intercom unit to a flat surface by drilling four mounting holes and installing the enclosed #6 fasteners. Mounting hole and intercom dimensions are shown below. The unit is designed for vehicle interiors and indoor use. Do not mount outdoors.

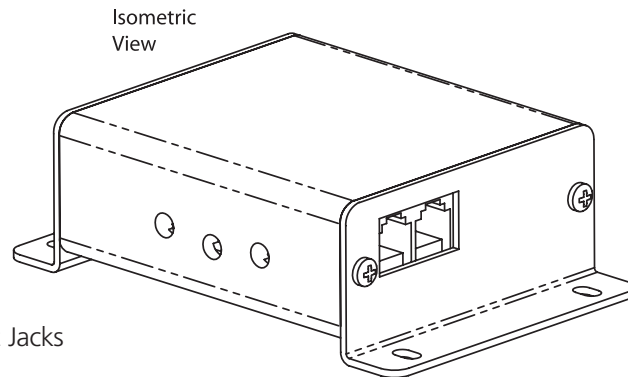

Assembly Shown without Jacks  
Units: Inches [millimeters]  
Scale: None

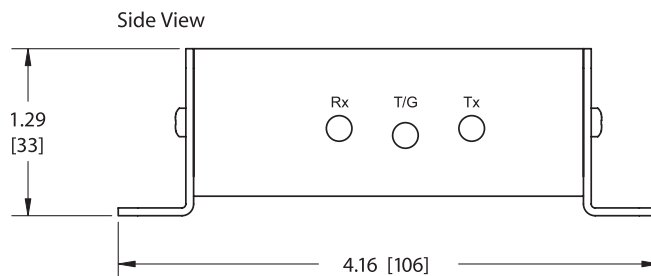
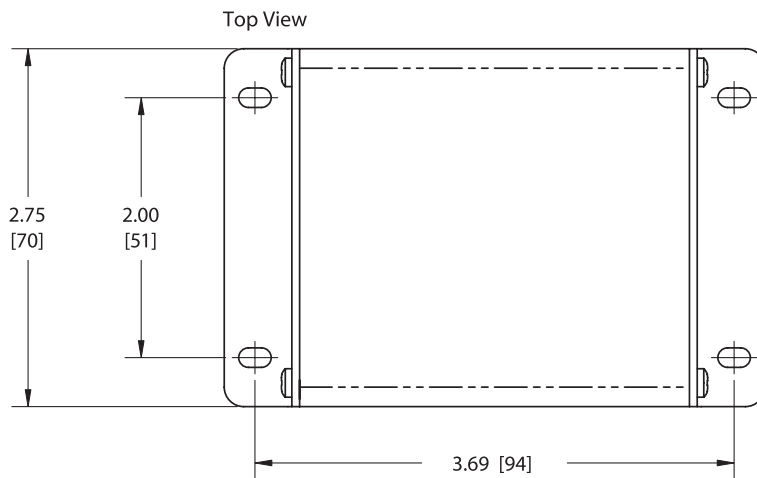

# SYSTEM WIRING

## Overview

Once the intercom is installed, the system is ready for wiring. Headset modules are connected to the intercom port using RJ-12 connectors and CA cables as shown in the figure below. See **“CA Cable Routing”** in the **System Wiring** section of this manual before wiring. A 2-way radio may be added using the 9-pin D-Sub connector.

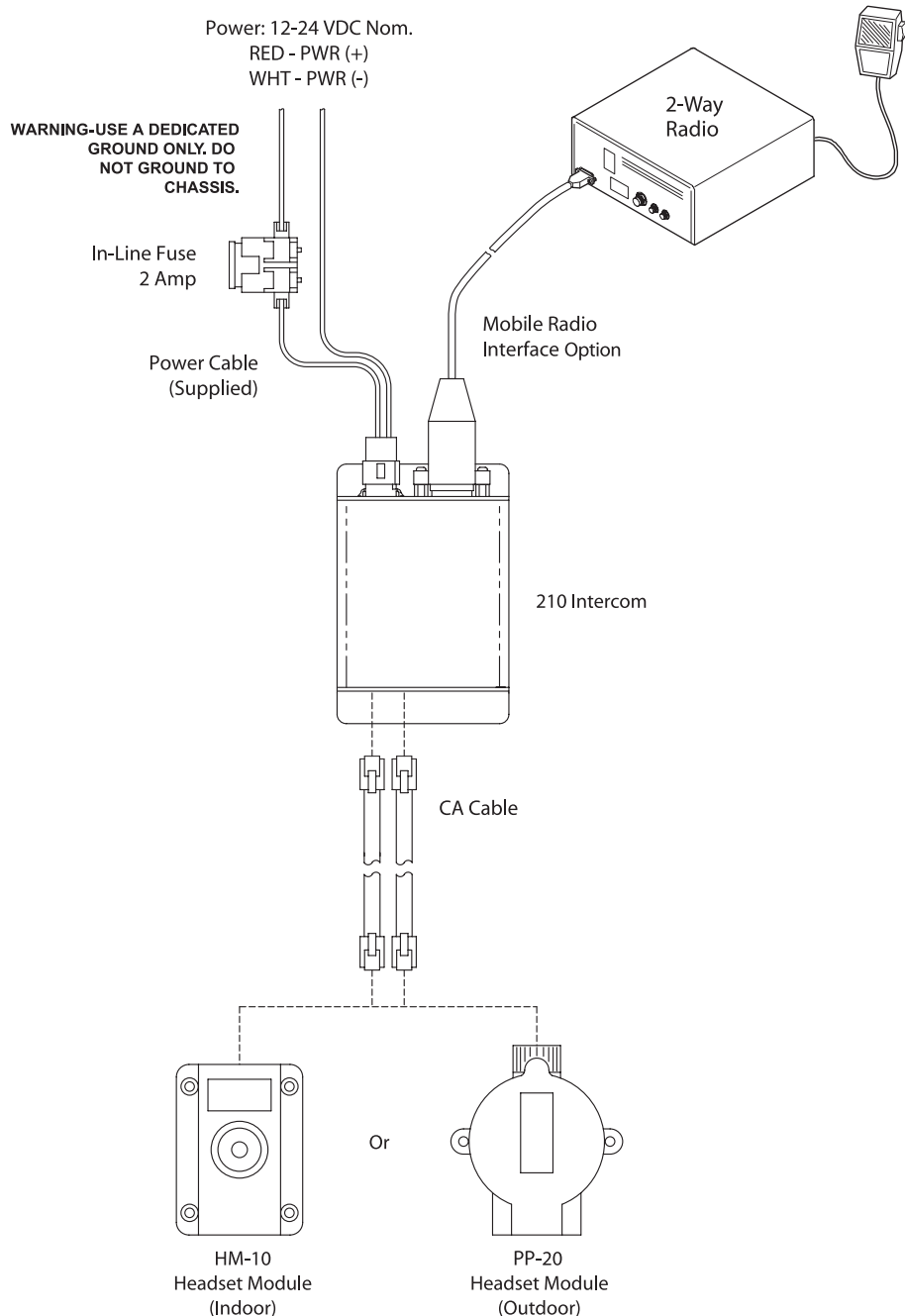

## SYSTEM WIRING

### Power Connections

Power is wired to the intercom using the power supply cable with in-line fuse (included). When routing the power cable, the in-line fuse should be easy to access.



#### Warning

**Before making power connections, make sure the power source is turned off.**

#### Important

**Use a dedicated ground for the (-) power connection. Do not ground to the chassis.**

#### Important

**We recommend connecting the intercom power to the same power busses as the 2-way radio.**

### CA Cable Routing

There are several important considerations when routing the CA cable:

- Do not bundle extra cable. The cable should be cut to length at installation, especially when radios are used.
- Route CA cables away from hot surfaces including vehicle exhaust systems.
- When routing CA cables through bulkheads or other sheet metal, use a grommet in the hole to prevent damage to the cable.
- A radio transmit priority "PR" port is identified on the front of the intercom. When a radio is connected to the system, the intercom user on this port will have priority when transmitting over the radio. Other users will not be able to transmit over the radio while this user is transmitting.

### Headset Module Installation

The following steps are recommended for installing a HM-10 or PP-20 headset module.

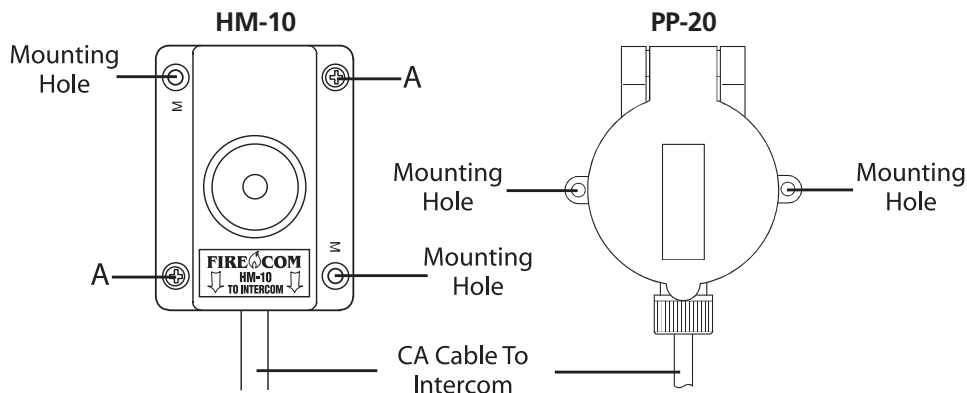

- Identify where the headset module is to be mounted and use the module as a template to locate the two mounting holes as shown in figure above. Drill two holes for the #6 hardware provided.
- If you are installing a PP-20 module, route the CA cable as outlined in "CA Cable Routing" on this page and install an RJ-12 connector at the intercom end of the cable as outlined in Appendix B "RJ-12 Connector Assembly." **Always make sure the printed side of the cable is facing the release tab on the RJ-12 modular plug.** If you are installing an HM-10 module continue with the following steps.



## SYSTEM WIRING

### Headset Module Installation

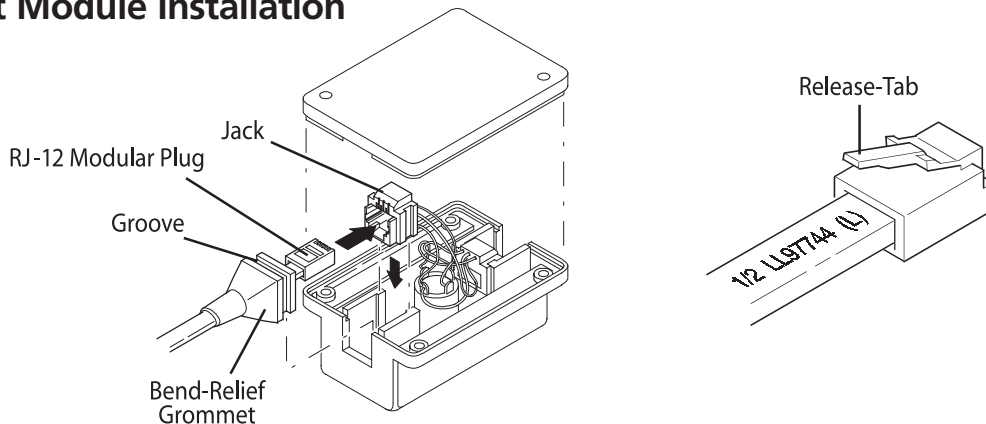

- With the CA cable routed from the intercom, cut the cable to length at the headset module and slide the bend relief grommet over the end of the CA cable as shown in the figure above.
- Attach a RJ-12 connector to the end of the cable –see Appendix B “RJ-12 Connector Assembly.” **Always make sure the printed side of the cable is facing the release tab on the RJ-12 modular plug.**
- Open the headset module assembly by removing the screws labeled “A” in the figure on page 6. Install the plug and bend relief grommet as shown in the figure above. **If the CA cable is going from the intercom to the headset module it MUST be inserted on the same side of the HM-10 as the “Firecom” label.** Replace the headset module cover and mount the assembly with the hardware provided.

### Daisy-Chaining Headset Modules

Under certain circumstances daisy-chaining of headset modules may be used to increase the number of headset positions available. However the following requirements must be met:

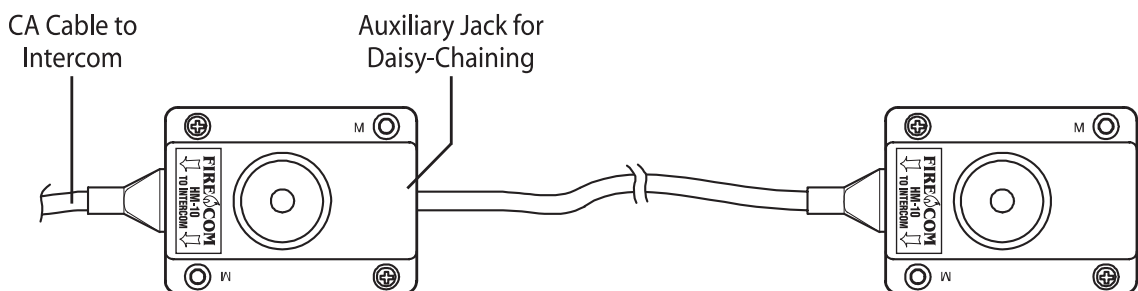

- **Headset modules in a daisy-chain must be connected in a specific manner as illustrated in the figure above. The CA cable from the intercom should always be plugged into the headset module on the “Firecom” label side.** You will need to remove the plastic tab which covers the access hole to the auxiliary jack to add the CA cable to the next headset module.
- **Do not mix headset types** in a daisy-chain (intercom-only vs. radio transmit).
- **A maximum of two intercom-only headsets** may be used in a daisy-chain.
- **A maximum of one radio-transmit headset** may be used in a daisy-chain.

## SYSTEM WIRING

### Foot Switch (optional)

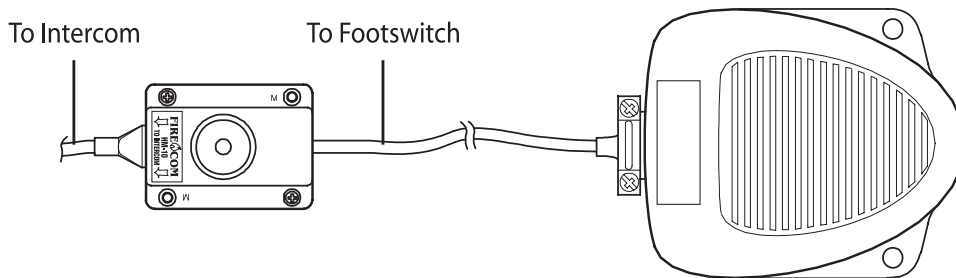

A radio Push-to-Talk (PTT) foot switch option is available from Firecom when a headset radio PTT is not desired. The foot switch is installed to the headset module in a similar fashion as the headset module daisy-chain installation. See “**daisy-chaining headset modules**” in the **System Wiring** section of this document. Depressing the foot switch will initiate radio transmissions of the headset plugged into the headset module where the foot switch is installed.

The foot switch is installed to the headset module using a CA cable and RJ-12 connector. You will need to open the headset module and remove the plastic tab which covers the access hole to the second modular jack.



#### Warning

The CA cable from the intercom should always be plugged into the headset module on the “Firecom” label side.

### Radio Connections

A mobile radio may be connected to the intercom by using the radio port on the back of the unit. A MR interface cable, with an un-terminated end, is supplied with the intercom. For independent wire descriptions, see Appendix A.



#### Warning

To ensure proper operation, the connection to the radio should be performed by a qualified radio technician.

Some radio specific interface cables are available for common model radios. For a list of interface cables, please visit [www.firecom.com](http://www.firecom.com) and click on the Product Support section of our web site or contact our service department at 800-527-0555.

When installing an MR cable, tighten the two screws on the plug of the cable.



#### Warning

If the screws are not properly tightened, the 9-pin plug may vibrate and cause problems with transmission, reception, or other radio functionality.

# SETTINGS

## Setting Options

Side View

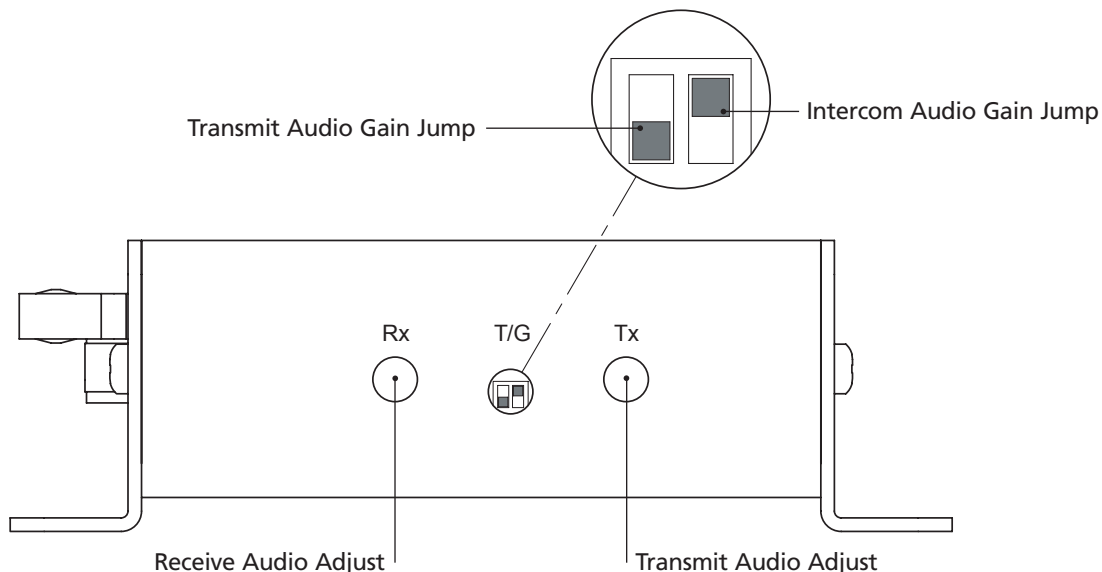

Several adjustments to the 210 intercom are required. When connecting to a mobile radio it will be necessary to make both transmit and receive audio adjustments.



### Warning

**These adjustments must be performed by a qualified radio technician. Failure to perform these adjustments may result in problems hearing or transmitting radio signals when using the intercom system.**

### RX

The receive audio adjustment is a rotational adjustment of the audio gain from the radio. When making this adjustment, set your mobile radio volume to the normal volume level used without an intercom installed. The audio level should be adjusted with other intercom users for quality audio mixing.

### Transmit Audio Gain Jump

The transmit audio gain jump switch is an incremental gain increase of the audio broadcast through the radio. The gain is increased when the switch is in the "up" position and decreased in the "down" position. The Transmit Audio "TX" should be used initially for adjustment and the Transmit Audio Gain jump used only if required.

### Intercom Audio Gain Jump

The intercom audio gain jump switch is an incremental gain increase of the intercom sound level. Each headset is also equipped with an independent volume control. If an overall higher intercom sound level is desired, the intercom audio gain jump switch may be used. The gain is increased when the switch is in the "up" position and decreased in the "down" position.

### TX

The transmit audio adjustment is a rotational adjustment of the audio broadcast through the radio. Adjust the radio transmit sound level to eliminate clipping and provide quality audio mixing.

After these adjustments are made, the holes may be sealed using plugs (provided).

## OPERATION

The 210 intercom is designed to offer clear, full-duplex communication between participants. In addition, mobile radio communication is possible when connected to Firecom's 210 intercom.

Before testing the intercom, make sure the power supplied to the intercom is turned on. If a radio is connected to the intercom, confirm that it has power as well.

To begin using the intercom, plug your Firecom headset into a headset module. For proper headset fitting instructions, as well as care and maintenance, see your headset manual.

Firecom offers many different styles of headsets for use with the 210 intercom system including over-the-head and under-the-helmet styles. Either of these styles can be intercom-only headsets or radio-transmit headsets.

### **Radio-transmit Headsets**

Radio-transmit headsets are identified by a red momentary PTT button on the headset. These headsets receive both intercom and radio communications at all times. The mic is always active for intercom communications, while the red PTT button is used to transmit over the radio. When you speak into the microphone you will hear yourself in the headset speakers. Volume is adjusted on the ear dome. You will hear other participants on the intercom as well as radio traffic when a radio is installed with the system.

### **Intercom-only Headsets**

Intercom-only headsets are identified with either a black momentary or yellow latching PTT button on the headset. These headsets receive both intercom and radio communications at all times, but are not capable of radio transmission. Headsets with black momentary PTT buttons require the user to push and hold the PTT button to talk over the intercom. Headsets with yellow latching PTT buttons require a user to push the button once to talk over the intercom and press again to end audio transmissions. When the PTT button is activated and you speak into the microphone, you will hear yourself in the headset speaker. Volume is adjusted on the ear dome. You will hear other participants on the intercom as well as radio traffic when a radio is installed with the system.

### **Foot Switch (optional)**

If an optional foot switch is installed, any headset plugged into the headset module attached to the foot switch will transmit over the radio when the foot switch is activated. See **System Wiring** section, "**Foot Switch (optional)**" in this manual.

When a mobile radio is connected to the intercom, radio traffic will be heard in the headset speakers. The volume level of the radio traffic should be similar to the intercom audio volume level – see the Settings section of this manual for adjustment.

One of the two headset intercom ports on the intercom is a radio transmit priority "PR" port – see the "**CA Cable Routing**" in the **System Wiring** section in this manual. When a mobile radio is connected to the system, the intercom user on this port will have priority when transmitting out the radio. Other users will not be able to transmit over the radio once this user is transmitting.

## TROUBLESHOOTING

If the intercom system does not operate as expected, check the following items:

- Check for power at the intercom and confirm that the fuse is not blown or the circuit breaker is not tripped.
- Confirm that a dedicated ground is used for the intercom power and not a chassis ground.
- Check for corrosion on headset plugs.
- Check that the headsets are plugged in all the way.
- Check headset controls.

If these steps do not correct the problem, review the chart below for symptoms and recommendations.

SYMPTOM	RECOMMENDED SOLUTION
Intermittent crackling in headset speakers	<ul style="list-style-type: none"> <li>• Check the headset plug. Make sure it is clean for best electrical contact.</li> <li>• Check wire connections at the headset module.</li> <li>• Check wire connections at the intercom.</li> <li>• Check the CA cable and RJ-12 connectors.</li> </ul> <p><b>Tip:</b> Determine if the problem is with the headset or the headset module by plugging the headset into another module and retesting.</p>
Alternator whine and other distracting noises	<ul style="list-style-type: none"> <li>• Connect both the intercom and radio to the cleanest power source possible, without sirens, strobes, flashers, and motors (i.e. wipers, heater, etc.).</li> <li>• Check the power and ground connections for both the intercom and the radio. Make sure they are clean and tight.</li> <li>• Ensure that power and ground wires for the radio and intercom are no smaller than 18 AWG.</li> <li>• Check MR cable for proper wiring connections.</li> <li>• Make sure that all battery connections are clean and free from dirt and corrosion.</li> <li>• Use separate noise filters on radio and/or intercom power as needed.</li> <li>• Use a robust common ground for both the radio and the intercom.</li> </ul> <p><b>Tip:</b> Check the power to the intercom for an AC signal. There should be less than 300mVAC present on power lines.</p>
No sound in headset speakers	<ul style="list-style-type: none"> <li>• Check the volume control on the headset.</li> <li>• Check the headset plug. Make sure it is clean for the best electrical contact.</li> <li>• Confirm that the intercom has adequate power.</li> <li>• Check wire connections at the headset module.</li> <li>• Check wire connections at the intercom.</li> <li>• Check the CA cable and RJ-12 connector installation.</li> </ul> <p><b>Tip:</b> Determine if the problem is with the headset or the intercom system by plugging the headset into another headset module and retesting.</p> <p><b>Tip:</b> Substituting suspect components in the system may be helpful in tracking down problems.</p>
You can hear others on the intercom, but they cannot hear you	<ul style="list-style-type: none"> <li>• Confirm that you have the headset microphone close to your mouth; within 1/8 inch is recommended.</li> <li>• If you have an intercom only headset, press the PTT button on your headset. See the <b>Operation</b> section of this manual for PTT activation details.</li> <li>• Check the headset plug. Make sure it is clean for the best electrical contact.</li> <li>• Check wire connections at the headset module.</li> <li>• Check wire connections at the intercom.</li> <li>• Check the CA cable and RJ-12 connector installation.</li> </ul>

## TROUBLESHOOTING

You can't hear others on the intercom, but they can hear you	<p><b>Tip:</b> Determine if the problem is with the headset or the intercom system by plugging the headset into another headset module and retesting.</p> <p><b>Tip:</b> Substituting suspect components in the system may be helpful in tracking down problems.</p> <ul style="list-style-type: none"><li>• Check the headset volume control setting.</li><li>• Check the headset plug. Make sure it is clean for the best electrical contact.</li><li>• Check wire connections at the headset module.</li><li>• Check wire connections at the intercom.</li><li>• Check the CA cable and RJ-12 connector installation.</li></ul>
The headset speaker has sound from the intercom but not the radio or the radio receive audio is weak	<p><b>Tip:</b> Determine if the problem is with the headset or the intercom system by plugging the headset into another headset module and retesting.</p> <p><b>Tip:</b> Substituting suspect components in the system may be helpful in tracking down problems.</p> <ul style="list-style-type: none"><li>• Check the radio volume</li><li>• Adjust the receive audio setting. See the <b>Settings</b> section in this manual.</li><li>• Verify that receive audio is present by listening to the radio's speaker.</li><li>• Check the MR cable between the radio and the intercom. Make sure the screws on the 9-pin D-sub connector are tight. See <b>Appendix A</b> for wire connection details.</li></ul>
The radio keys but no audio is transmitted or the radio transmitted audio is weak	<ul style="list-style-type: none"><li>• Check the affected headset location for faulty connections or components.</li><li>• Adjust the transmit audio setting. See the <b>Settings</b> section in this manual.</li><li>• Check the MR cable between the radio and the intercom. Make sure the screws on the 9-pin D-sub connector are tight. See <b>Appendix A</b> for wire connection details.</li></ul> <p><b>Tip:</b> Determine if the problem is with the headset or the intercom system by plugging the headset into another headset module and retesting.</p> <p><b>Tip:</b> Substituting suspect components in the system may be helpful in tracking down problems.</p>
The radio doesn't key	<ul style="list-style-type: none"><li>• Check the affected headset location for faulty connections or components.</li><li>• Check the CA cable and RJ-12 connector installation.</li><li>• Check the MR cable between the radio and the intercom. Make sure the screws on the 9-pin D-sub connector are tight. See <b>Appendix A</b> for wire connection details.</li></ul> <p><b>Tip:</b> Determine if the problem is with the headset or the intercom system by plugging the headset into another headset module and retesting.</p> <p><b>Tip:</b> Substituting suspect components in the system may be helpful in tracking down problems.</p>

If a problem persists in a headset or intercom unit, contact Firecom for a Return Merchandise Authorization (RMA) number. Return the headset or intercom for replacement or repair.

Contact:

**Firecom Corporation**  
7340 SW Durham Road  
Portland, OR 97224 USA  
800-527-0555 OR 503-684-6647

## OPTIONS AND ACCESSORIES

See [www.firecom.com](http://www.firecom.com) for options and accessories.

## SPECIFICATIONS

Dimensions:

L x H x W: 4.16 [106] x 2.75 [70] x 1.29 [33] inches [millimeters]

Weight::

5.9 oz (without cables)

Power Requirements:

Minimum: 9.5 VDC @ 83mA

Maximum: 28.0 VDC @120mA

Fuse: 2 amp

See the headset manual for headset specifications.

## Appendix A - Wiring Diagrams

### 5 Conductor Plug

5 Conductor Plug

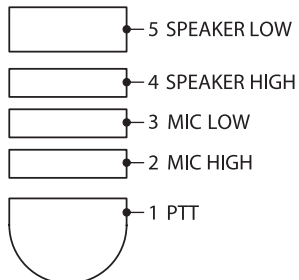

### HM-10 Headset Module

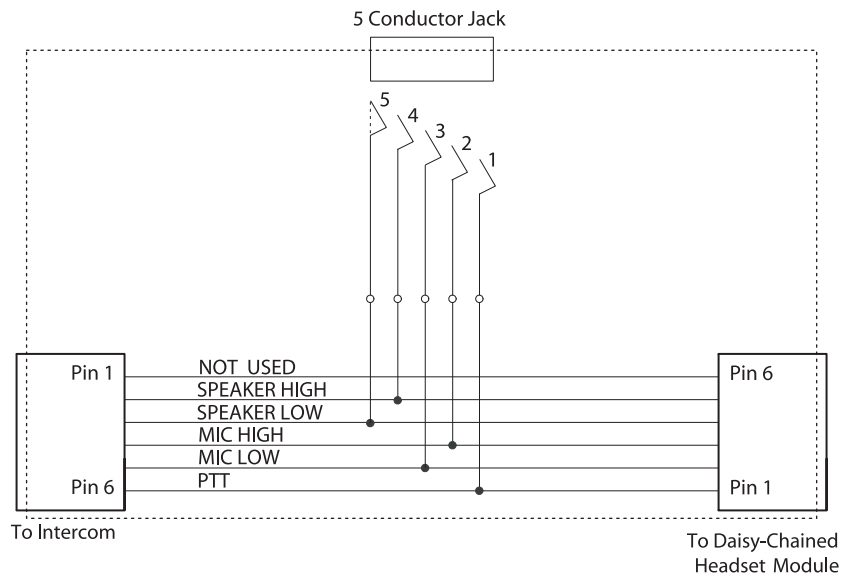

# Appendix A - Wiring Diagrams

## PP-20

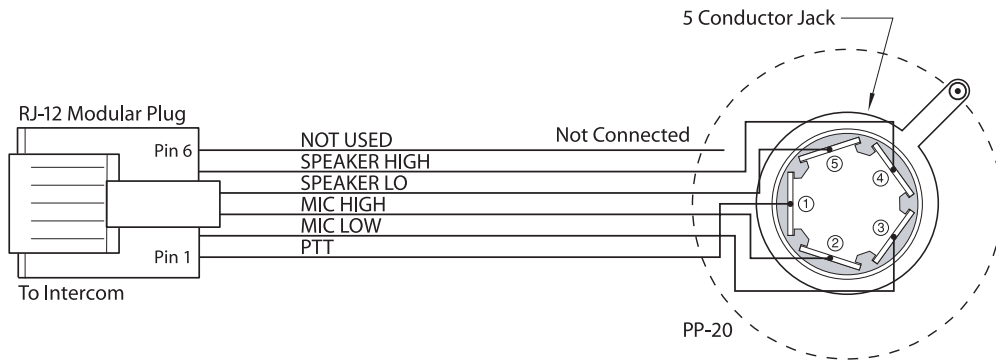

## CA Cable

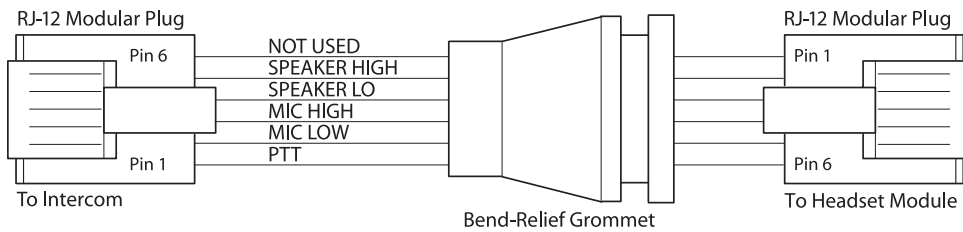

## Mobile Radio Interface Cable

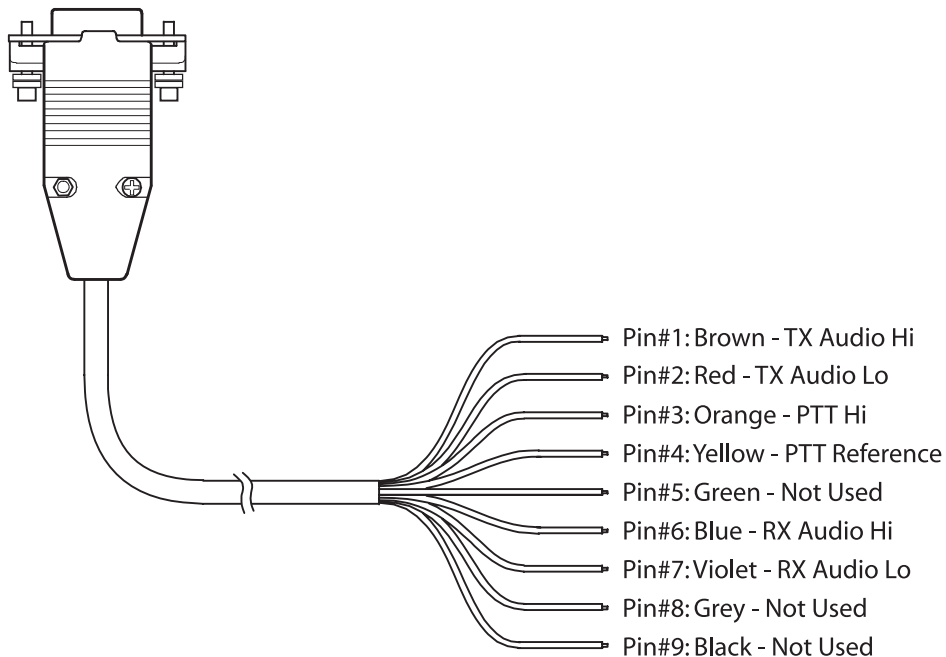



## Appendix B - RJ-12 Connector Assembly

### RJ Connector, 6 Position Plug Installation

To install the RJ-12 connector plug onto the flat CA cable:

1. Using the cutter blade on the crimping tool (labeled A, in figure 1), cut the CA cable so the cut is clean and at a 90-degree angle to the side of the cable.
2. Fully insert one end of the CA cable between the stripping blades (labeled C, in figure 1) until the end of the cable hits the stop (labeled B, in figure 1).

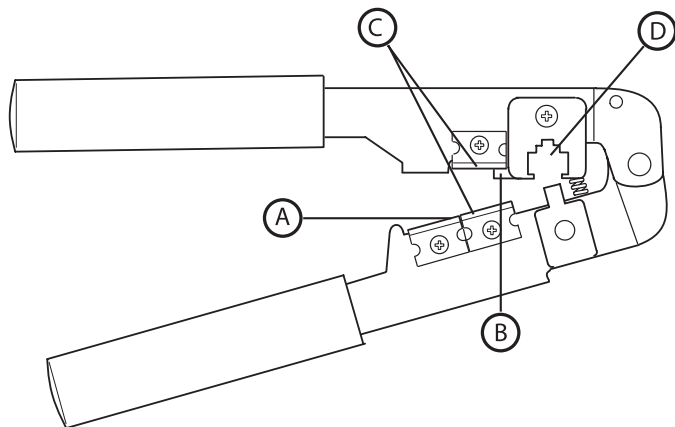

Figure 1  
RJ Connector Plug  
Crimping Tool

3. Squeeze the handles of the crimping tool together until the tool bottoms out.
4. While holding the handles together, pull the cable out of the tool.
5. The stripped insulation should expose approximately 3/16" of wire (figure 2).
6. Push a RJ-12 connector into the plug holder on the crimping tool (labeled D, in figure 1) until the release tab on the plug locks into position.
7. Holding the cable so that the printed side of the cable is toward the release tab on the plug, push the cable into the plug as far as it will go.

Figure 2  
Stripped  
CA Cable

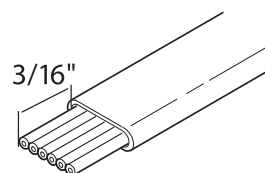
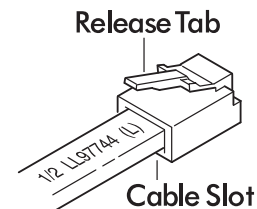

Figure 3  
RJ-12 Connector  
Plug

**Note: Always make sure the printed side of the cable is facing the release tab on the RJ-12 connector plug (figure 3). This ensures proper orientation of the plug on each end of the cable.**

8. Squeeze the tool handles completely together. You may feel the crimper finish punching the contacts through the insulation on the wires.
9. Let the handles spring open.
10. Push down on RJ-12 connector release tab (figure 3) and remove the RJ-12 connector from the crimping tool.
11. Inspect the plug to ensure that the cable is held securely in place.
12. Repeat this procedure as necessary to install a RJ-12 connector plug on each end of each CA cable.



## WARRANTY

### Two-Year Limited Warranty to the Original Purchaser

Sonetics Corporation warrants to the original purchaser of its products, that they will be free from defects in materials and workmanship, under normal and proper use, for the period of two years from date of purchase. Sonetics Corporation will repair or replace, at its option, any parts showing factory defects during this warranty period, subject to the following provisions. This warranty applies only to a new product which has been sold through authorized channels of distribution. All work under warranty must be performed by Sonetics Corporation. All returned products must be shipped to our address, freight prepaid, accompanied by a dated proof of purchase. The purchaser voids this warranty if he, she or others attempt to repair, service or alter the product in any way. This warranty does not apply in the event of accident, abuse, improper installation, unauthorized repair, tampering, modification, fire, flood, collision, or other damage from external sources, including damage which is caused by user replaceable parts (leaking batteries, etc.). This warranty does not extend to any other equipment or apparatus to which this product may be attached or connected. The foregoing is your sole remedy for failure in service or defects. Sonetics Corporation shall not be liable under this or any implied warranty for incidental or consequential damages, nor for any installation or removal costs or other service fees. This warranty is in lieu of all other warranties, express or implied, including the warranty of merchantability or fitness of use, which are hereby excluded. To the extent that this exclusion is not legally enforceable, the duration of such implied warranties shall be limited to two years from date of purchase. No suit for breach of express or implied warranty may be brought after two years from date of purchase.





**FIRECOM IS A DIVISION OF SONETICS CORPORATION**

17600 SW 65th Ave, Lake Oswego, OR 97035 USA  
800-527-0555 • [service@firecom.com](mailto:service@firecom.com) • [firecom.com](http://firecom.com)

Copyright ©2019 Sonetics Corporation. All rights reserved.  
The information in this document is subject to change without notice.  
No part of this document may be reproduced in any form without prior written consent of Sonetics Corporation.